

qorvo

Power Up Your Design

Qorvo® Multi-time Programmable
PMIC Solutions



Connecting, protecting and powering the world.

Qorvo's PMICs are efficient and highly integrated solutions that perform power distribution functions in complex systems with multiple power rails. Multiple time programmable (MTP) non-volatile memory (NVM) enables configurability to adjust functions and parameters that can be preprogrammed and optimized on-the-fly using an I2C interface.

Multi-time programmable PMICs, same PMIC different configurations



Why Qorvo Power ICs?

- ActiveCiPS™ – Qorvo’s proprietary multi-time programmable technology (Configurable Intelligent Power Solutions)
- ActiveCiPS reduces your design risk with on-board design changes on the spot, in your lab
- A single device delivers multiple configurations for different designs
- ActiveCiPS accelerates your time to market
- Fully integrated cost-effective solution

Tools

- ActiveCiPS programming dongle
- Easy to use GUI
- Allows you to reconfigure ICs on your PCB

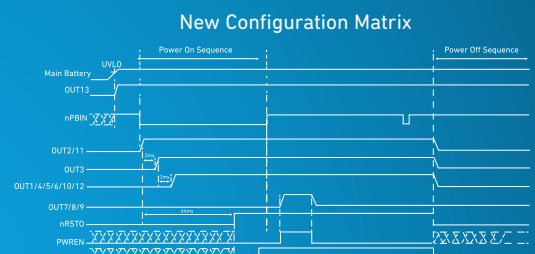
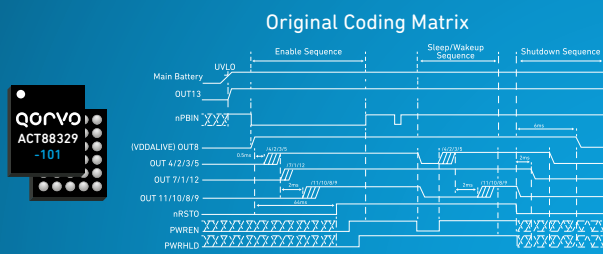

OPTIMIZED FOR EVERY PROJECT



ACT88760

The ACT88760 is a 5V integrated PMIC. It delivers advanced levels of programmability, power efficiency and capability in a simple, compact design.

Key Features

- Wide 2.7-5.5V input voltage range
- 13 integrated rails, a sequencer and 10 general purpose IOs (GPIOs) provide industry-leading flexibility
- Dual phase outputs for high current
- High PSRR LDOs
- High configurability via I2C interface
- Debug designs and change settings in real-time without changing external components
- 3.85x3.85 mm 81 ball WLCSP package

End markets: AI processors, mobile, solid-state drives (SSDs), virtual reality headsets, security and action cameras, image processing, laptops, AR/VR headsets.

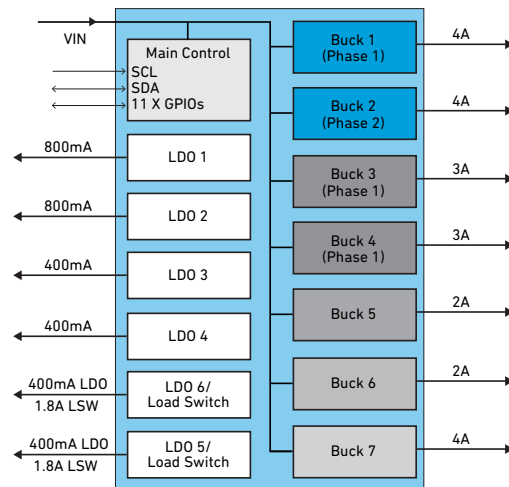

FIND OUT MORE
www.qorvo.com/go/ACT88760



ACT88420

The ACT88420 is a 5V integrated PMIC. It includes constant-on-time (COT) control topology for improved transient response, and three-state GPIOs for enhanced configurability. This highly compact device is ideal for space-constrained designs.

Key Features

- Wide 2.7-5.5V input voltage range
- Six integrated rails, sequencer
- 8 configurable GPIOs
- Optimized quiescent current and light load efficiency
- Multiple sleep modes
- 2.7x2.7 mm 36 ball WLCSP package

End markets: IoT, SSD, HH terminals, controller boards, communication cards, point of sale terminals and networked cameras.

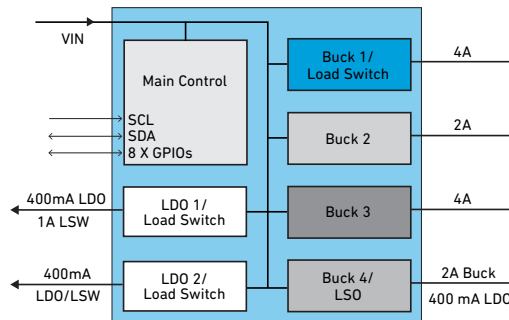

FIND OUT MORE
www.qorvo.com/go/ACT88420



ACT81460

The ACT81460 is a fully integrated, low-power multi-rail PMIC with an integrated 1S battery charger. It features very low standby current that prolongs battery life and is specially designed for the wearable market.

Key Features

- Wide 4-5.5V input voltage range with 20V protection
- 10 output rails
- 6uA quiescent current
- High integration and configurability give greater design flexibility
- I2C serial interface for easy programming
- Multiple low power modes
- 3.3x3.3 mm 49 pin WLCSP package

End markets: Wearables, medical devices, electronic tags, IoT modules, security cameras.

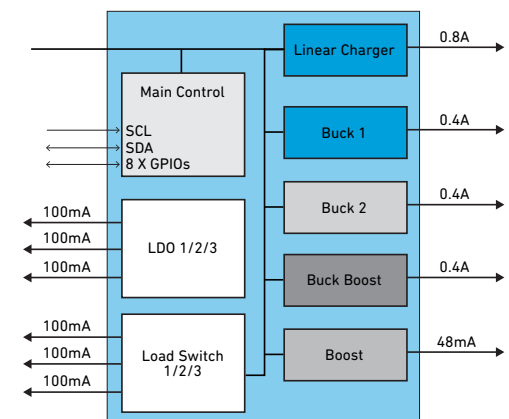

FIND OUT MORE
www.qorvo.com/go/ACT81460



ACT88329

The ACT88329 is a 5V integrated PMIC delivering high power, high density and support for advanced low-power modes.

Key Features

- Wide 2.7-5.5V input voltage range
- 5 integrated rails, a sequencer and 7 general purpose IOs
- GPIOs provide industry-leading flexibility
- I2C serial interface for monitoring and control
- Small WLCSP package 2.18x2.58 mm
- Multiple sleep modes
- ACT88321 package alternative to support TH vias for PTH boards

End Markets: AI processors, mobile, solid-state drives (SSDs), virtual reality headsets, security and action cameras, image processing, laptops, AR/VR headsets, servers.

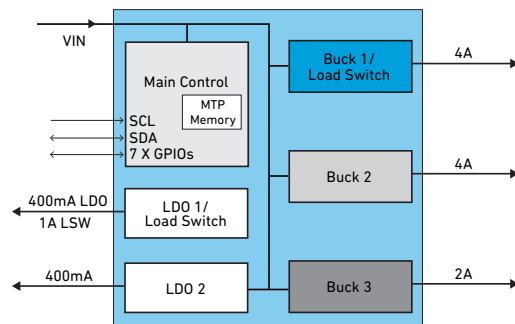

FIND OUT MORE
www.qorvo.com/go/ACT88329



ACT43x50

The ACT43x50 series are a configurable GaN bias point autocalibration power solution. Qorvo's compact, three-stage power solution for phased array system designs provides configurable GaN bias point autocalibration and flexibility to optimize system performance for different GaN power amplifiers (PAs) without changing the board design. The ACT43750 combines the drain switch and negative gate regulator to create a highly configurable chipset that supports bias sequencing and autocalibration of the GaN PA for aging and temperature compensation.

Key Features

- Bias sequencing
- Autocalibration for temperature and aging compensation
- Reduced capacitance: only 100uF needed for 1KW pulse
- Configurable Vdrain: 20V-55V up to 20A
- Drain switching below 100ns
- Minimized noise and EMI

End Markets: Phased array, radar

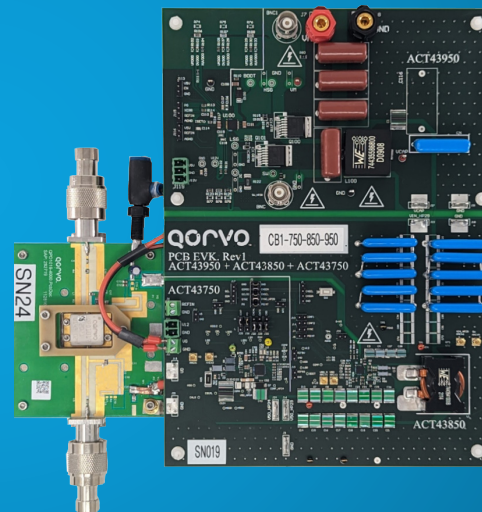

FIND OUT MORE
www.qorvo.com/go/phased-array-power



FOR MORE INFORMATION

www.qorvo.com/go/pmics